



**Pallet fork  
for Loader and  
backhoe Loader**

**Pallet fork  
for Skid-Steer Loader**





## Technical Specification



Pallet forks, for Skid-Steer Loader, Loader or Backhoe Loader with manual side shift frame and protection grid (only in Skid-Steer Loader model)

**2 high lifting capacity forks** manual with manual side shift.

# Pallet fork

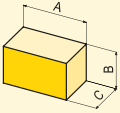
		Skid - Steer Loader				Loader and Backhoe Loader		
MODEL		PF 100	PF 120	PF 130	PF 150	PF 250	PF 450	
<b>Technical specification</b>	um							
Max lifting capacity <sup>(1)</sup> Q	kg	1000		1800	2500	2500	4500	
Weight standard configuration	kg	120	145	185	230	260	380	
Forks section ExF	mm	80x30		100x35	100x40	100x40	120x50	
Forks length C	mm	1000		1100	1200	1200		
Frame width L	mm	1000	1200	1300	1500	1500		
Frame height H	mm	900	950			450	540	
Center of gravity B	mm	500				500		
	ton	1,3-1,6	1,6-2,6	2,6-3,5	3,4-4,8	-	-	
	ton	-	1,5-3,0	2,8-4,0	4,0-6,2	4,0-6,2	6,0-12,0	
	ton	-	2,0-3,4	3,0-4,6	4,5-6,5	4,5-6,5	6,2-9,0	
	Overall size in standard configuration	A cm	100	120	130	150	150	
		B cm	90	95	95	95	54	54
		C cm	110	121	131	141	124	125

<sup>(1)</sup> Maximum lifting capacity "Q" is for load centre of gravity in central position between the forks.

## WORKING DIMENSIONS

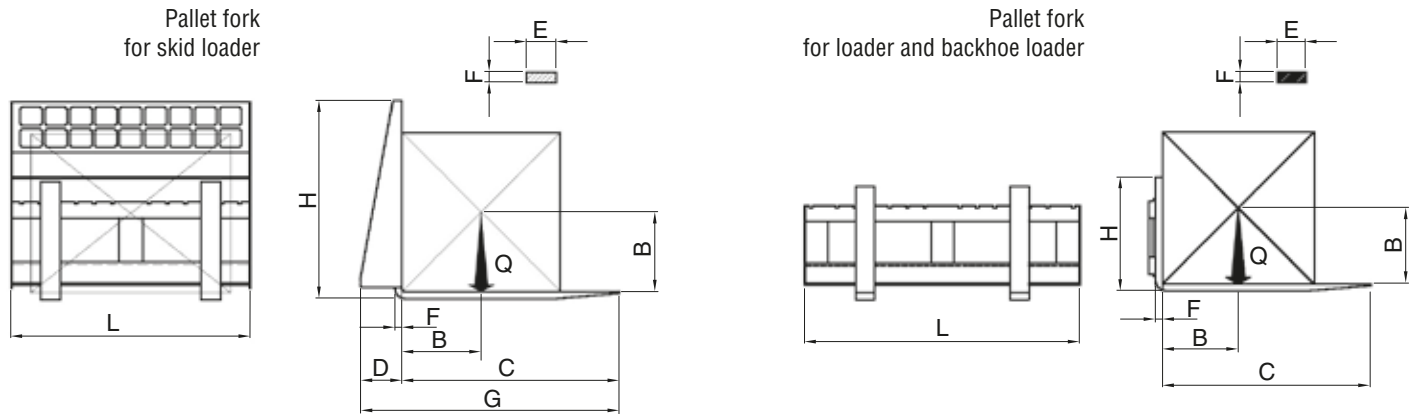

## ACCESSORIES FOR OPERATING MACHINES



Via E. Mattei, 4 - 48012 Bagnacavallo RA - Italy  
 tel + 39 0545 62712 fax +39 0545 62140  
 info@gfgordini.com - www.gfgordini.com

**we move earth**

